

SYSTEM OVERVIEW

The Telesis® TMM4250/470 PINSTAMP® is a high-speed, multi-pin marking system that permanently prints messages into a variety of materials such as steel, aluminum, and plastic. Hardened pins are pneumatically accelerated to indent dot matrix characters into the item being marked. The shape, size, density, and location of characters are determined by the user through the system software. The marking head moves the pin cartridge through X- and Y-axis motions to reach the correct position for each dot of the characters to be marked. The system software automatically controls pneumatic pin extension and retraction to mark the message.

The **TMM4250 Marking Head** includes the mechanical motion components to position the marking pins at precise X/Y positions and the pneumatic components to drive the marking pins from, and return the pins to, the pin cartridge.

The TMM4250 marking head is an X/Y-traversing mechanism. Using two stepper motor drives, it accurately positions the pin cartridge at coordinate-defined locations in marking window within .008mm (in Fine mode) and .032mm (in Standard mode). The TMM4250 uses a rack-and-pinion drive system to rapidly position the pin cartridge and to accommodate the rigorous dynamics of impacting and rebounding.

The floating pin design permits consistent, high-quality marks, even on irregular, slightly curved surfaces. It also accommodates applications where marking surfaces cannot be positioned at a consistent distance from the marker.

A **Protective Boot** is installed around the pin cartridge assembly to help prevent contaminants from entering the marking head cavity. The nitrile (synthetic rubber) boot is especially helpful for applications that require additional protection against splashing liquids, sprays, and mists.

Vented Case. An air line can be connected to the tube fitting in the top of the marker and routed to a clean, dry environment. This allows the marker to breathe clean, dry air in an otherwise dirty environment.

Pin Cartridges. The standard system uses non-lubricated, lightweight pin cartridges for the 25S-series and 150SA-series pins. Cartridges for 25S pins are available in two configurations: four (4) pins spaced on 6mm centers or on 12mm centers. The cartridge for 150SA pins contain two (2) pins spaced on 25mm centers. The cartridge configuration dictates the size of the marking window along the X-axis. Refer to the marking head installation drawing for details.

Marking Pins. The TMM4250 uses 25S-series and 150SA-series marking pins available in various cone (tip) angles. The 25S-series pins are made of powdered steel stainless steel with diamond tips or carbide. The 150SA pins are made of powdered steel or tool steel with carbide tips. Refer to the marking head installation drawing for pin stroke (pin extension) dimensions.

The **Marker Cable** connects the marking head to the controller. The highly flexible cable is 4m (13.1 ft.) long and attaches to the back of the marker with a quick disconnect connector. Optional extension cables lengths are available.

The **Filter/Regulator Unit** includes two regulators with pressure gauges to control drive air and return air. The first regulator contains a filter to help remove contaminants from the supply air. Two air lines connect the regulated air to the marking head. Drive air fires the impact pin; return air pushes it back into the cartridge. Standard air lines are 4m (13.1 ft.) long made of 6mm tubing.

The **TMC470 Controller** provides the electrical interface and software control of the TMM4250 marking head. (Refer to *TMC470 Controller Specifications* for details.)

TMM4250/470 Marking System

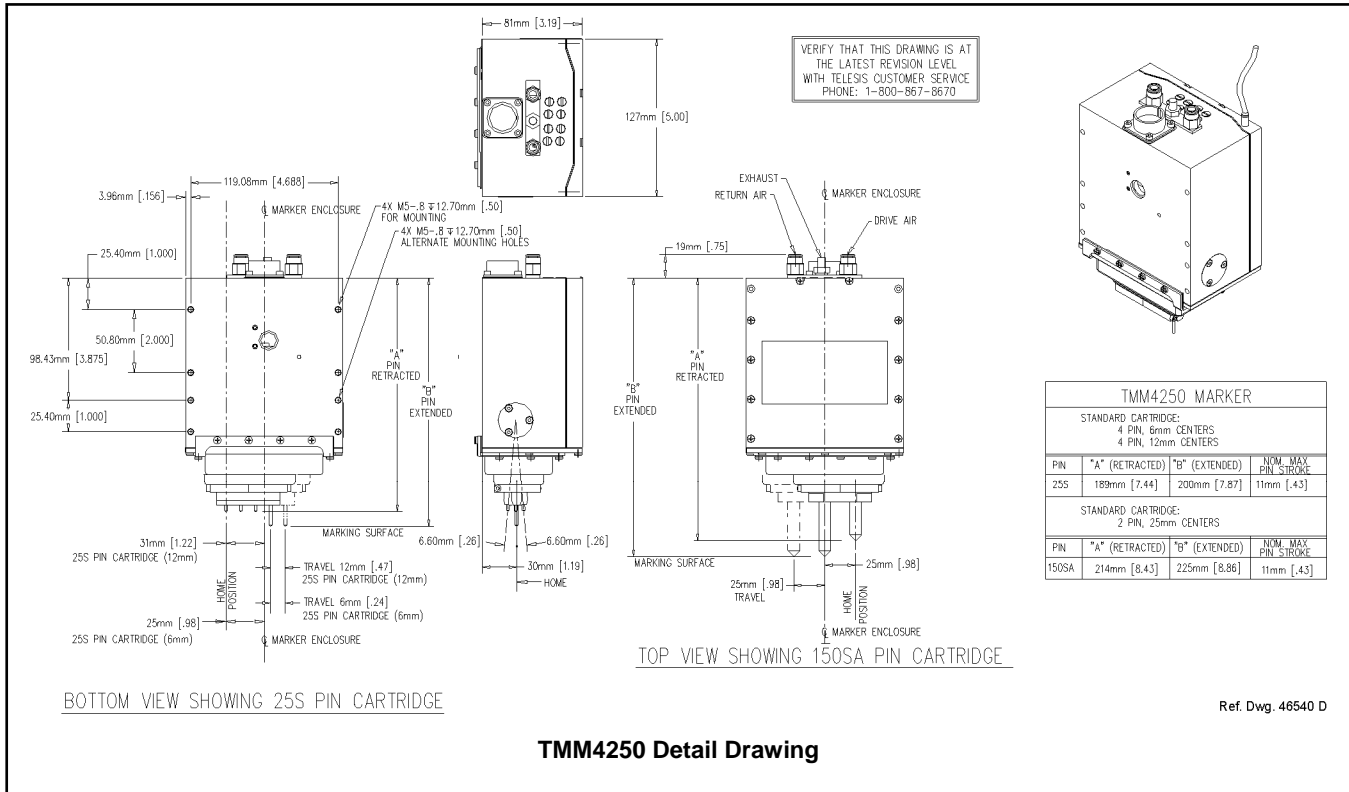

TMM4250 Detail Drawing

SYSTEM SETUP

- When designing a fixture, allow for 3-axis adjustment to aid in horizontal, vertical, and lateral alignment of the marking head.
- Mount marking head to a suitable fixture using four M5-0.80 bolts. **Mounting bolts must not extend into marking head more than 10mm (0.39 in.).**
- Mount filter/regulator assembly, using brackets provided, within 4m (13.1 ft.) of marking head.
- Connect drive air and return air lines to the connectors on back of marking head.
- Connect supply air to input port on filter/regulator assembly.
- Locate controller as close as practical to marking head. Standard marker cable length is 4 m (13 ft.).
- Install the controller as a table-top, wall-mounted, panel-mounted, or enclosure-mounted unit, as applicable.
- Ensure controller power switch is OFF.
- Connect marker cable to controller.
- Connect power cable to controller.
- Position controller power switch to ON.
- Start marking system software.
- Adjust pin stroke, drive air, and return air for impact depth.
Nominal drive air pressure 5.5 bars (80 psi)
Nominal return air pressure 1.5 bars (20 psi)

CAUTION

The TMC470 is not a sealed unit. Protect it from potentially damaging conditions and contaminants. Do not block vents in bottom of case. Ensure the marking system is electrically isolated from any devices that may generate extreme electromagnetic interference (EMI).

SYSTEM OPTIONS

- Tool Post Assembly
- Marking Head Extension Cables
- TMC470 Controller Wall-mounting Bracket Kit
- TMC470 Controller Panel-mounting Bezel/Bracket Kit
- TMC470N NEMA® Enclosure
- Bar Code Scanner or Bar Code Wand with Cable
- Foot Switch (Start Print) or Pushbutton Station (Start/Abort)
- Backup Utility Software
- Upgrade Utility Software
- Logo/Font Generator Software

TMM4250 MARKING HEAD

Specifications

The TMM4250 marking head specifications are subject to change without prior notice.

Dimensions.....	see illustrations
Rating	NEMA 13 (I.P. 65)
Weight	2.22 kg (4.89 lb) including boot; excluding marker cable, pin cartridge, & tooling
Operating Temperature.....	0° to 50°C (32° to 122° F), non-condensing
Air Supply	Clean and dry, 4.2 to 8.3 bars (60 to 120 psi)
Air Consumption	0.15 L/sec (0.32 SCFM) idle 0.28 L/sec (0.60 SCFM) marking
Marking Area.....	see illustrations
Pin Types.....	25S-series, various cone (tip) angles 150SA-series, various cone (tip) angles
Pin Material.....	Powdered Steel or Stainless Steel with Diamond Tips or Carbide (25S- series) Powdered Steel or Tool Steel with Carbide Tips (150SA-series)

Marking Characteristics

The TMM4250 can produce characters as small as 0.75mm (0.03 in.) high. Text strings may be rotated 180° to print inverted. Characters can be printed with resolutions from 4 to 79 dots/cm (10 to 200 dots/in.) for an engraved look. The depth of mark can be adjusted over a significant range by adjusting the pin stroke and, to a lesser extent, by adjusting the drive air pressure. Three marking modes are available to optimize quality and speed. Raster mode prints side-to-side, indexing downward one row at a time. Matrix mode prints up and down, indexing one column at a time. Continuous mode prints with only one pin at a time, tracing the character shape.

Marking Speeds

The system is capable of marking eight (8) characters per second (two characters per pin per second) using a four-pin cartridge to print 3mm (0.118 in.) high characters in the 5x7 font. Speeds will vary widely depending on the selected character size, style, and dot density. Specific times can be verified by a Telesis representative.

Marking Noise

Although every attempt is made to reduce noise, the material being marked significantly influences the noise level. For example, marking a solid lead block produces less noise than marking a thin-walled steel pipe.

Pin Life

Pin life depends largely on the type of material being marked, how hard or abrasive it is, and the required marking depth. On typical metals with a hardness of Rockwell Rb47, marking at a depth of .127mm (0.005 in.), powdered steel pins average about 3 million impressions before needing sharpened.

TMM4250/470 Marking System

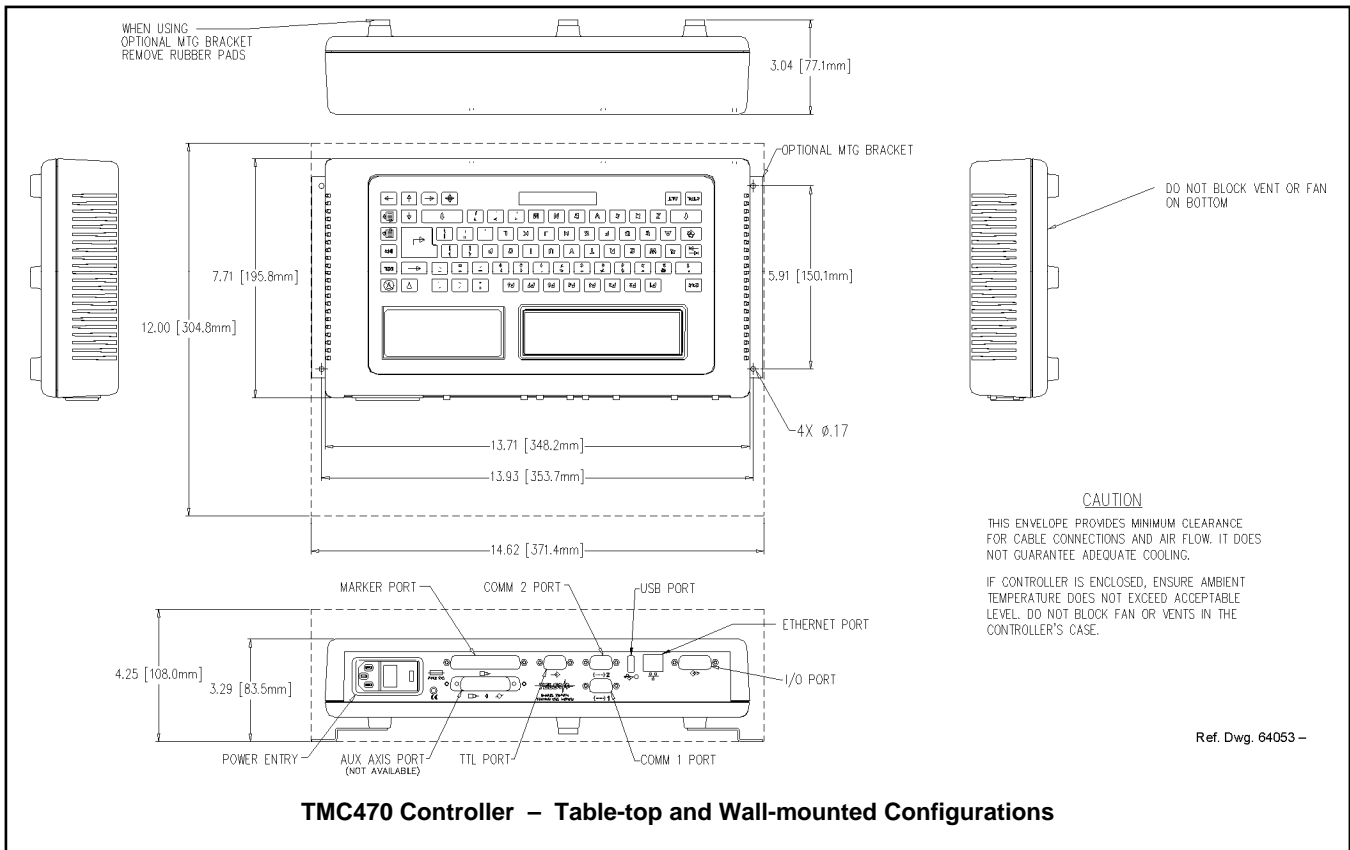

TMC470 CONTROLLER

The TMC470 controller may be installed as a table-top unit, a wall-mounted unit, a panel-mounted unit, or an enclosure-mounted unit. All configurations provide features and connectivity for external communications. Differences occur only in the mounting configuration.

TMC470 Specifications

The TMC470 Controller specifications are subject to change without prior notice.

Compliance	CE, RoHS
Configurations	Table-top, Wall-mounted, Panel-mounted, or Enclosure-mounted
Rating	NEMA 1 (I.P. 30) table-top or wall-mounted NEMA 12 (I.P. 65) panel-mounted using customer-supplied panel NEMA 12 (I.P. 65) using Telesis-supplied TMC470N enclosure
Dimensions	refer to TMC470 Mounting Drawings
Weight	3.69 lb. (1.68 kg) controller only 3.90 lb. (1.77 kg) with wall-mount kit 5.52 lb. (2.51 kg) with panel-mount kit 28.1 lb. (12.77 kg) with TMC470N enclosure

TMC470 Specifications (continued)

Op. Temperature	32° to 122° F (0° to 50°C)
Op. Humidity	10% to 80% non-condensing
Cooling	Internal, thermostat-controlled fan
Power Requirements	95 to 250 VAC, 2 amps, 50-60 Hz, single phase
Communications	TTL, Discrete I/O, RS232, RS485, TCP/IP, and USB (data backup and data transfer)
Input Signals	Twelve (12) total, 8 dedicated, 1 programmable, 3 available 10 VDC (minimum voltage) 30 VDC (maximum voltage) 12 to 24 VDC (nominal voltage) 2.3 mA @ 12VDC; 4.9 mA @ 24VDC (nominal current)
Output Signals	Six (6) total, 4 dedicated, 2 available 0.25 amps (maximum current) 0.50 ohms (maximum On resistance) 40 VDC (maximum line voltage) 12 to 24 VDC (nominal line voltage)

TMM4250/470 Marking System

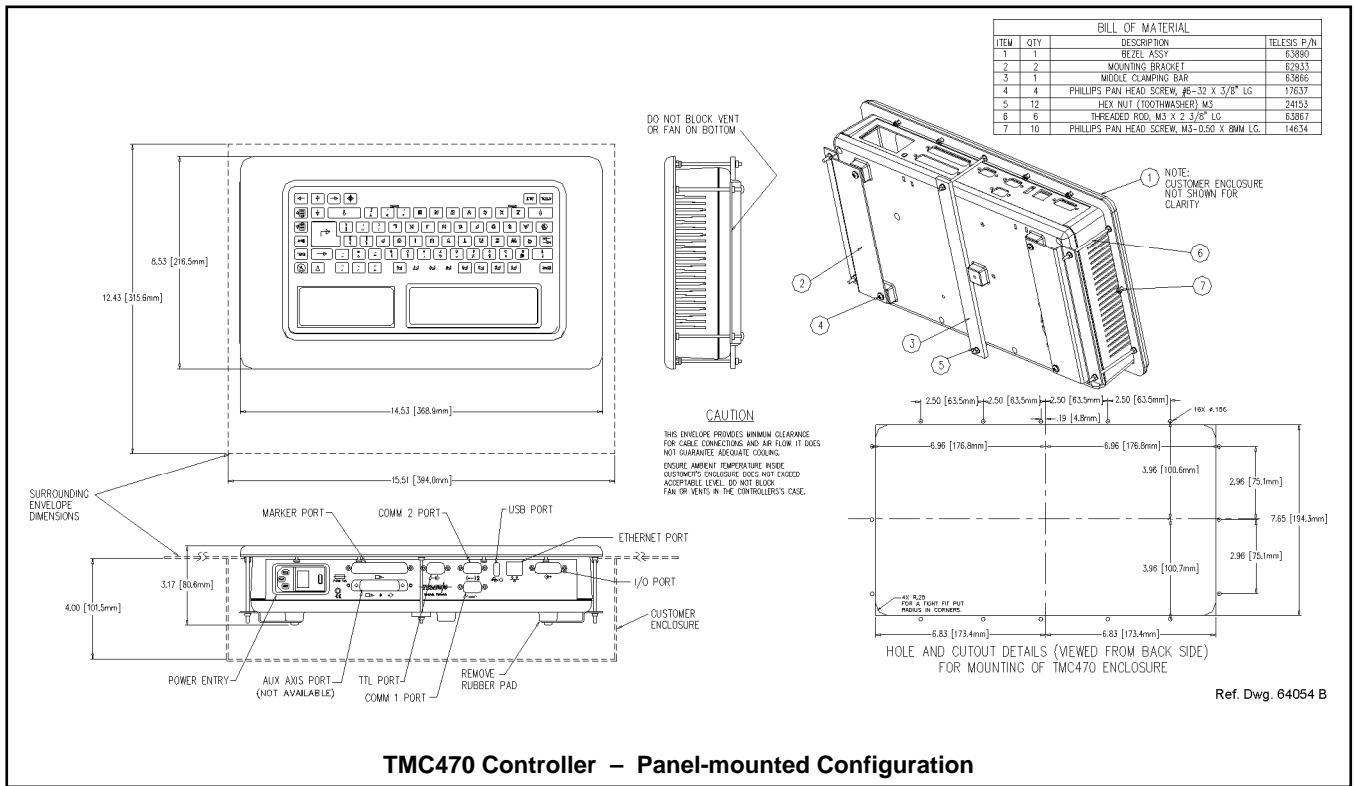

TMC470 Controller – Panel-mounted Configuration

Environmental Considerations

The following environmental considerations must be taken into account when installing the TMC470 Controller.

Contaminants. The vented TMC470 is rated NEMA 1 (IP30) and contains a thermostatically-controlled, variable speed fan. Accordingly, in environments where solid and/or liquid contaminants are present, the possibility exists that these contaminants can be drawn into the TMC470 controller and possibly result in failure. For that reason, in these types of environments, the controller must be located in a sealed industrial enclosure. To facilitate such installations, Telesis offers an optional panel mounting kit for use with an appropriate customer-supplied panel or enclosure. Telesis also offers an optional TMC470N NEMA 12 (I.P. 65) enclosure in which the controller can be mounted.

EMI Susceptibility. Although the system has been found to be in compliance with pertinent susceptibility standards, care should be taken when installing near welders and other extreme generators of electromagnetic interference (EMI). Particular care should be taken to ensure welder currents are not injected through the marking head chassis. The marking head chassis is connected to the electrical service earth ground through the marking head cable. The marking head should be electrically isolated from all surfaces which could become part of a welder current path.

TMC470-based System Software

The system software is permanently installed in the controller. It provides the user interface for the operator to control the marker. The software also provides a library for storing, loading, and editing user-defined patterns. Patterns are files stored in the controller's memory. Depending on the size of the pattern files, the controller can store up to 200 patterns. Each pattern contains one or more fields; each field defines a single object. Printable objects may be created to define text strings, arc-text strings, geometric shapes, graphics, and machine-readable data matrix symbols. Non-printable objects may be defined to specific commands to the marker (e.g., Pause, Go to, Input, or Output). Printable text fields may include alphanumeric characters, symbols, and special message flags. Message flags automatically insert data into the text string, such as serial numbers, times, dates and user-defined codes.

TMM4250/470 Marking System

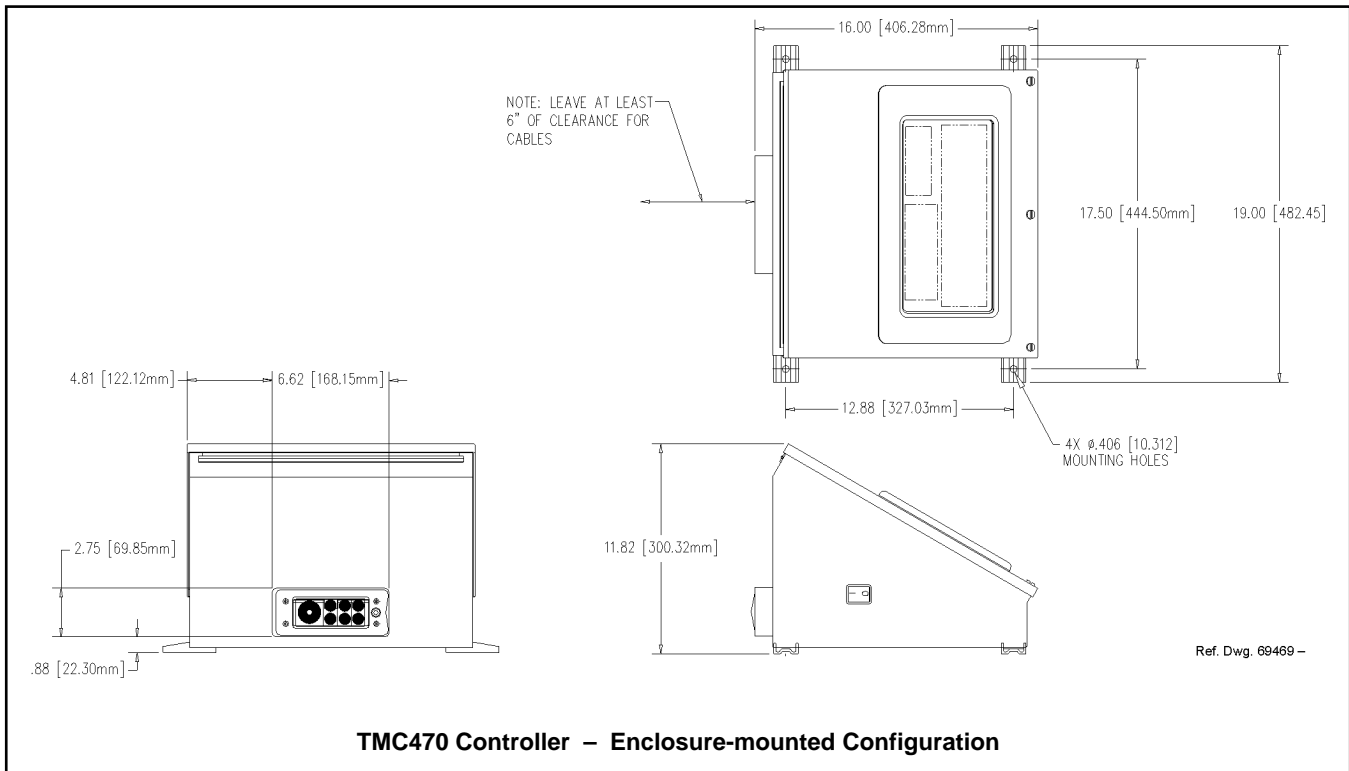

Interface Panel

The back panel of the controller provides various ports for connecting the marker, host computers, logic controllers, optional accessories, and remote I/O devices. See below.

Serial Interface. The Comm 1 and Comm 2 Ports allow connection to remote serial devices such as a host computer or a bar code scanner. See Host Communications for details.

Discrete I/O Interface. The I/O Port allows you to connect a Programmable Logic Controller (PLC) or other DC I/O source for remotely controlling marker operations. See Discrete I/O Controls for details.

TTL Interface. The TTL Port allows the system to connect with a simple contact closure circuit such as a remote push button station or foot pedal switch. These types of devices can remotely control Start Print and Stop Print operations.

TCP/IP Interface. The Ethernet Port typically connects to a PC over a local area network (LAN). It allows you to define the controller as a client or a server socket using Telesis Extended Protocol. See Host Communications for details.

USB Interface. The USB Port allows you to connect a memory stick/flash drive for pattern storage/retrieval and for software upgrades.

Discrete I/O Controls

The TMC470 is configured for 12 VDC to 24 VDC I/O only and is provided to connect a PLC or other DC I/O source. The I/O Port allows you to remotely select and load patterns, start printing, stop printing, place the marker online, and monitor the system output signals. Cable connectors and connector pins are supplied with the controller for constructing appropriate interface cables.

Input Signals. These input signals provide the following controls:

INPUT COMM.....	For all inputs (+ or – supply)
START PRINT	Begins print cycle
STOP	Stops the print cycle
SEL_0 thru _6 *	Remotely selects & loads up to 127* pattern files
SPARE_1, 2, 3.....	Three (3) spares for custom applications

* System software allows SEL_6 signal to be configured for remotely selecting patterns or for remotely placing the marker online. If used for marker online, pattern selection is reduced to 63 patterns (max).

Output Signals. These output signals indicate the following states:

OUTPUT COMM.....	For all outputs (+ or – supply)
DONE	Print cycle is complete
READY	System ready for message or for start print command
PAUSED	System paused (waiting timeout or command)
NO FAULT	System status (normal or fault detected)
SPARE_1, 2.....	Two (2) spares for custom applications

Host Communications

The marking system software allows you to configure communication parameters to transmit and receive data to and from a host computer. To provide maximum integration flexibility, the system software supports RS-232 and RS-485 serial interfaces and Ethernet TCP/IP interfaces. The system software also provides two protocol choices: Programmable Protocol and Extended Protocol.

RS-232 Interface. The serial (RS-232) communications interface is most often used with remote devices such as host computers, terminals, or bar code scanners. The Comm 1 RS-232 interface supports both Telesis Extended Protocol and Telesis Programmable Protocol. The Comm 2 RS-232 interface supports only Telesis Programmable Protocol.

RS-485 Interface. The RS-485 interface is normally used for long transmission distances or multi-drop networks of up to 31 TMC470 controllers. You must use Telesis Extended Protocol with the RS-485 interface.

The following describes the serial data character format on all transmissions to and from the TMC470 Controller.

- Asynchronous
- 1200, 2400, 4800, 9600, 19200, 38400, or 115200 Baud
- 1 or 2 Stop Bits
- 7 or 8 Data Bits
- None, Even or Odd Parity

TCP/IP Interface. The Ethernet (TCP/IP) interface is most often used with host computers communicating over a local area network (LAN). You must use Telesis Extended Protocol with the TCP/IP interface.

The Port parameter identifies the host computer socket that is assigned to the marking system. If more than one marking system is installed in a network configuration, each system must use a separate and unique port number. The Address parameter identifies the IP address of the host computer. The marking system software supports both fixed addressing and dynamic addressing.

Programmable Protocol. Use this protocol where very simple one-way communications are required (such as with bar code scanners). Programmable Protocol provides no error checking or acknowledgment of the transmitted data. Note that XON/XOFF Protocol applies even when Programmable Protocol is selected.

Starting Character specifies where the software begins to count character positions. This number must be entered in ASCII decimal format such as 2 for STX.

Terminating Character identifies the end of transmitted string (usually ASCII carriage return character, decimal 13).

Character Position counted from the starting character ignoring all characters preceding it.

Character Length accepts variable length messages (if set to 0) or messages of a pre-specified, fixed number of characters.

Ignore Character identifies the character to ignore when sent from the host (usually ASCII line feed character, decimal 10).

Message Type allows message-type recognition which defines how the marking system will use data it receives from the host.

- 49** Message type 49 (1) overwrites first text field with data extracted from the host
- 80** Message type 80 (P) loads a specific pattern identified by data extracted from host
- 81** Message type 81 (Q) updates text in first query buffer with data extracted from host
- 86** Message type 86 (V) updates first variable text field with data extracted from host
- 0** Message type 0 (zero) indicates that host will provide message type, field number (if applicable), and data; delegates message type selection to the host on message-by-message basis. The host message must use the format:

Tnn<string>

where:

- T** = 1, P, Q, or V to indicate message type
- nn** = two-digit field number or query text buffer where data will be placed. (Note: No number is used with Message Type P.)
- <string>** = field data (Message Types 1, Q, or V) or pattern name (Message Type P)

Extended Protocol. This protocol selection includes error checking and transmission acknowledgment. It should be used in applications where serial communication is a vital part of the marking operation. All communications are carried out in a parent/child relationship with the host being the parent. Only the host has the ability to initiate communications. If the host does not receive a response within three seconds, it should re-transmit its original message. If no response is received after three tries, it should declare the link to be down.

TMM4250/470 Marking System

Extended Protocol (continued)

The following describes the Extended Protocol message format as sent from the host to the TMC090 controller.

SOH TYPE [##] STX [DATA] ETX BCC CR

where:

- SOH** ASCII Start of Header character (001H). The controller ignores all characters received prior to the SOH.
- TYPE** A single, printable ASCII character that defines the meaning (type) and content of the message downloaded from the host, where:
- 1** Message Type 1 overwrites specified field of currently loaded pattern, using the data format nn<string> where nn is the field number.
 - P** Message Type P specifies pattern name to be loaded for printing
 - Q** Message Type Q updates specified query buffer with data received from host, using the data format nn<string> where nn is the buffer number.
 - V** Message Type V updates specified variable text field of currently loaded pattern, using the data format nn<string> where nn is the field number.
 - O** Message Type O resets marker and places it online
 - G** Message Type G initiates a print cycle to mark the currently loaded pattern
 - I** Message Type I requests the marker return the status of standard output and input signals. The system will return a hexadecimal code for the 6 output signals and 12 input signals in the following format:

OO ; III

where:

bit 1	READY	0x01
bit 2	DONE	0x02
bit 3	PAUSED	0x04
bit 4	NO_FAULT	0x08
bit 5	SPARE_1	0x10
bit 6	SPARE_2	0x20
bit 1	START	0x001
bit 2	STOP	0x002
bit 3	SEL_0	0x004
bit 4	SEL_1	0x008
bit 5	SEL_2	0x010
bit 6	SEL_3	0x020
bit 7	SEL_6 *	0x040
bit 8	SEL_4	0x080
bit 9	SEL_5	0x100
bit 10	SPARE_1	0x200
bit 11	SPARE_2	0x400
bit 12	SPARE_3	0x800

Note: Input SEL_6 may be configured to place machine online (default) or for Remote Pattern Selection.

[##] Two optional ASCII decimal digits that specify the Station ID number for use in multi-drop network applications. The ID may range from 00-31. Note that "00" is reserved for applications where only one controller is used. In such applications, this field may be eliminated and "00" will be assumed.

STX ASCII Start of Text Character (002H).

[DATA] Optional character string that may be required for certain message types (e.g., Type 1, P, Q, and V).

ETX ASCII end of text character (003H).

BCC Optional Block Check Code that is generated and sent to improve link reliability by providing fault detection. The BCC is calculated by taking an eight bit addition of the TYPE and DATA TEXT characters and transmitting them as a three digit ASCII decimal number in the range from 000 to 255. If the sum is greater than 255, the most significant bit overflows and is discarded.

CR ASCII Carriage Return Character (00DH).

TRADEMARKS

Telesis and **PINSTAMP** are registered trademarks of Telesis Technologies, Inc. in the United States.

NEMA is the registered trademark and service mark of the National Electrical Manufacturers Association.