

### SYSTEM OVERVIEW

The Telesis<sup>®</sup> BenchMark<sup>®</sup> 460 marking system permanently prints messages into a variety of materials such as steel, aluminum, and plastic. A hardened pin is accelerated to indent dot matrix characters into the item being marked. Character shape, size, density, and location are determined by the user through the marking system software.

The **Marking Head** is an electromechanical marker. The internal, mechanical components position the pin cartridge and an electric solenoid fires the marking pin. A spring returns the pin to its idle position within the cartridge. The marking head moves the pin cartridge through X- and Y-axis rectilinear motions to reach the correct position for each dot of the characters to be marked. The system software automatically controls pin extension to mark the message.

The marker uses two stepper-motor drives to rapidly and accurately position the pin at coordinate-defined locations in the marking window within 0.006 mm (0.00024"). The marker accommodates the rigorous dynamics of impacting, rebounding, and rapid positioning of the marking pin through a linear rail/ball bearing saddle assembly, ceramic-coated guide shaft/linear bushing assemblies, and drive motors with concentric, linear drive screws.

The lightweight and portable BenchMark 460 was designed for remote operation. The hand-held marker incorporates a pistol grip handle with a Start Print pushbutton switch. It can be used in virtually any orientation. The integral standoff with its padded front surface is held against the marking surface while marking. The standoff can be adjusted forward and aft to change the pin stroke.

The **Pin Cartridge**, machined from engineered plastic materials, offers long life with little maintenance. Screws attach the pin cartridge to the marking head for easy removal, cleaning, and pin replacement.

The **25XLE-series Marking Pins** are made of tungsten carbide and are available in 30° and 45° cone angles.

The **Marker Cable** connects the marker to the controller. The cable is 4 m (13 ft.) long and is pre-wired to the marking head.

The **BenchMark Controller** includes an integrated keyboard with a four line LCD display. It provides the electrical interface and software control of the BenchMark 460 marking head. Refer to *BenchMark Controller Specifications* for details.

### SYSTEM OPTIONS

- Controller Mounting Bracket Kit
- Foot Switch (Start Print)
- Pushbutton Station (Start/Abort)
- Bar Code Scanner or Bar Code Wand
- Logo/Font Generator Software
- Backup Utility Software
- Upgrade Utility Software
- Language Translation Utility Software
- BenchMark 460+ Enhanced Communications

# BenchMark460 Marking System

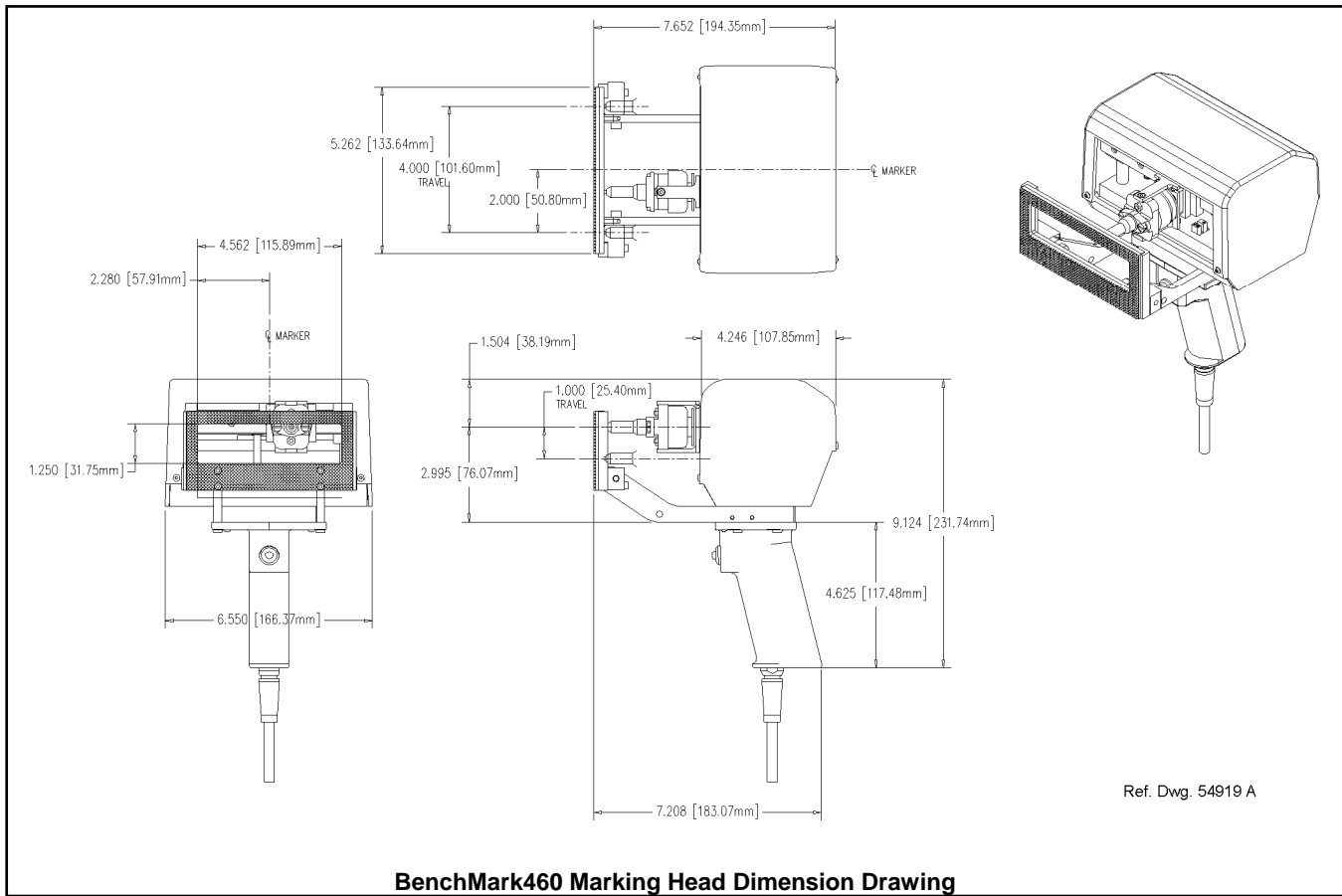

**BenchMark460 Marking Head Dimension Drawing**

## SYSTEM SETUP

1. Adjust standoff position to increase or decrease the pin stroke, as applicable, for proper pin impact depth.

### CAUTION

The controller is not a sealed unit. Protect it from potentially damaging conditions and contaminants. Do not block vents in bottom of case. Ensure the marking system is electrically isolated from any devices that may generate extreme electromagnetic interference (EMI).

2. Locate controller as close as practical to marking head. Standard marker cable length is 4 m (13 ft.).
3. Ensure controller power switch (on back panel) is OFF; connect power cable to controller.
4. Connect marker cable from marking head to controller; tighten securely.
5. Position controller power switch to ON (on back panel) to start the marking system software.

## BENCHMARK 460 MARKING HEAD

### Specifications

The BenchMark460 marking head specifications are subject to change without prior notice.

Dimensions.....	see <i>BenchMark Marking Head Dimension Drawing</i>
Weight .....	Marking Head: 1.58 Kg (3.47 lb.) Marker Cable: 0.80 Kg (1.76 lb.)
Operating Temperature .....	0° to 50° C (32° to 122° F), non-condensing
Marking Area .....	100 x 25 mm (4.0 x 1.0")
Pin Types.....	25XLE-series
Pin Material.....	Tungsten Carbide

### Marking Characteristics

The BenchMark460 can accommodate character sizes from .762 to 100 mm (.030 to 4.0") in .025 mm (.001") increments. Characters can be rotated 359° in 1° increments with a printing resolution range from 5 dots/cm (10 dots/in.) to 75 dots/cm (200 dots/in.) for an engraved look.

## BENCHMARK 460 MARKING HEAD *(continued)*

### Marking Speeds

The system will mark 2.3 characters per second (max.) using 5x7 font, 3 mm (.118") high, 2mm (.080") wide characters. Speeds will vary slightly depending on the selected character size, style, and dot density. Specific times can be verified by a Telesis representative.

### Marking Noise

Although every attempt is made to reduce noise, the material being marked significantly influences the noise level. For example, marking a solid lead block produces less noise than marking a thin-walled steel pipe.

### Pin Life

Pin life depends largely on the type of material being marked, how hard or abrasive it is, and the required marking depth. On typical metals with a hardness of Rockwell Rb47, marking at a depth of .127 mm (.005"), carbide pins average approximately 9 million impressions before needing sharpened.

### Marking Depth

The BenchMark 460 can obtain a marking depth of .127 mm (.005") in mild steel (Rb53) using a 25XLE carbide pin with a 45° cone angle. The depth of mark can be adjusted over a significant range by changing the impact force (software parameter) or the impact distance (pin stroke). Note that the maximum pin stroke distance is 4 mm (.15"). Specific depths can be verified by a Telesis representative.

### Vibration Data

Vibration tests were performed under controlled conditions imitating, as closely as possible, typical normal operation.

Conditions such as rigidity of the work piece, material, setting of the machine, etc. may vary in actual operational use and would alter the actual vibration level. Despite detailed guidance instructions provided with each machine, such conditions are beyond the control of Telesis and must remain the responsibility of the end user. Accordingly, you should conduct your own tests to establish safe working levels of use.

The vibration tests were conducted using the following parameters:

Drive Air Pressure .....	4.08 bars (60 psi)
Return Air Pressure.....	1.36 bars (20 psi)
Pin Stroke .....	8 mm (.31 in)
Marking Base.....	20 mm (.79 in) thick steel
Marking Surfaces .....	2 mm (.08 in) thick steel plate 4 mm (.16 in) thick aluminum plate
Marking Mode.....	Dot
Text Marked.....	TELESIS (11x16 font, 5mm [.20 in] characters) HHHEEE000888 (5x7 font, 3mm [.12 in] characters)

The following test results reflect the worst-case scenarios under the given test conditions.

Steel Marking Surface			
Pin	VM	T <sub>(EAV)</sub>	T <sub>(ELV)</sub>
25C	0.4 m/s <sup>2</sup>	more than 24 hr	more than 24 hr
150SA	0.8 m/s <sup>2</sup>	more than 24 hr	more than 24 hr
Aluminum Marking Surface			
Pin	VM	T <sub>(EAV)</sub>	T <sub>(ELV)</sub>
25C	0.6 m/s <sup>2</sup>	more than 24 hr	more than 24 hr
150SA	1.2 m/s <sup>2</sup>	more than 24 hr	more than 24 hr

where:

**VM** = hand/arm vibration magnitude.

**T<sub>(EAV)</sub>** = time to reach the *Exposure Action Value* based on continuous marking.

**T<sub>(ELV)</sub>** = time to reach the *Exposure Limit Value* based on continuous marking.

# BenchMark 460 Marking System

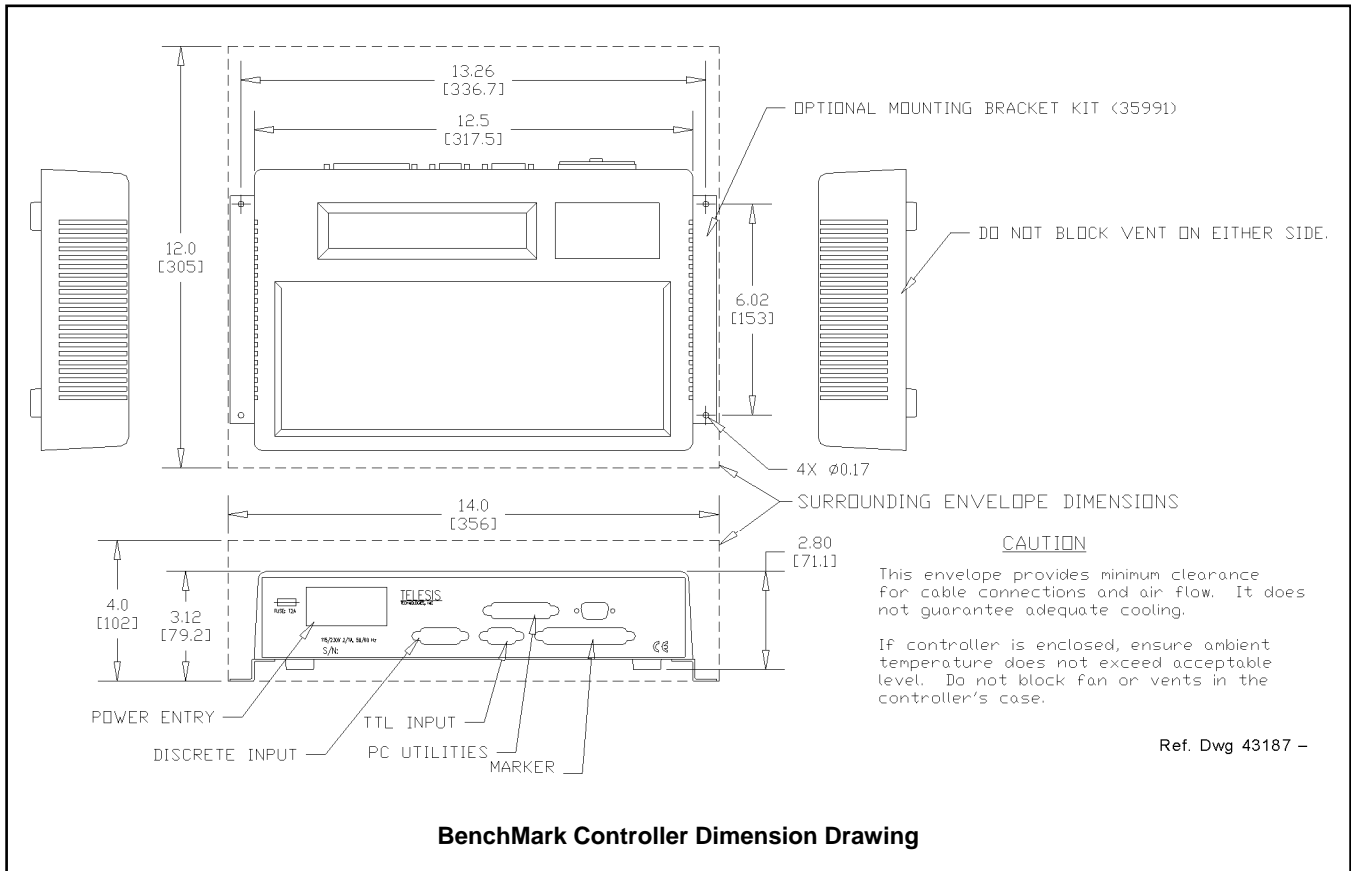

**BenchMark Controller Dimension Drawing**

## BENCHMARK CONTROLLER

### Specifications

The BenchMark controller specifications are subject to change without prior notice.

Dimensions .....	see <i>BenchMark Controller Dimension Drawing</i>
Rating .....	NEMA® 1 (I.P. 30)
Weight .....	2.15 Kg (4.75 lb.)
Operating Temperature.....	0° to 50°C (32° to 122° F), non-condensing
Required Power .....	95-130 VAC, 2 amps, 50-60 Hz single phase 200-250 VAC, 1 amp, 50-60 Hz single phase
Input Signals .....	12 to 24 VDC (optional, customer-supplied)

### Environmental Considerations

The following environmental considerations must be taken into account when installing the BenchMark controller.

**Contaminants.** The vented and fan-cooled controller is rated NEMA 1 (IP30). Accordingly, in environments where solid and/or liquid contaminants are present, the possibility exists that these contaminants can be drawn into the controller and possibly result in failure of a number of electronic components. For that reason, in these types of environments, the controller must be located in a sealed industrial enclosure.

**EMI Susceptibility.** Although the system has been found to be in compliance with pertinent susceptibility standards, care should be taken when installing near welders and other extreme generators of electromagnetic interference (EMI). Particular care should be taken to ensure welder currents are not injected through the marking head chassis. The marking head chassis is connected to the electrical service earth ground through the marking head cable. The marking head should be electrically isolated from all surfaces which could become part of a welder current path.

## BENCHMARK CONTROLLER *(continued)*

### Power and Marker Connections

The power entry module contains fuses for circuit protection and connects the controller to facility electrical power. The back panel also provides a Marker port for connecting the marking head. Input Control Signals. The controller is configured for VDC input only. The TTL Input port may be used to connect a remote foot switch or remote pushbutton station for Start Print commands. The Discrete Input port may be used for remote Start Print and Abort signals. Cable connectors and connector pins are supplied with the controller for constructing appropriate interface cables.

START PRINT ..... Input signal, begins print cycle  
ABORT ..... Input signal, aborts print cycle  
Input Comm..... For all inputs (+ or – supply)

### System Software

The marking system software is permanently installed in the controller. It provides the user interface for the operator to control the marker. The software also provides a library for storing, loading, and editing user-defined patterns. Patterns are files stored in the controller memory. The controller can store up to 75 patterns. Each pattern contains one or more fields. A field defines a single object and how it will be printed. Fields may define text strings, arcs, arc text strings, Go-To or Pause commands, or machine-readable data matrix symbols. Text fields may include alphanumeric characters, symbols, and special message flags. The message flags automatically insert data into the text string, such as serial numbers, times, and dates.

### Optional PC Utilities Interface

The Host port on the controller back panel is used for connecting to an optional, customer-supplied PC to access Telesis software utilities. Utility software may be used to backup patterns stored in the controller, to download a custom font to the controller, or to download controller software upgrades.

### Optional Bar Code Scanner Interface

The Host port also allows you to connect an optional bar code scanner. When the bar code scanner interface is used, the marking system reads the scanned data from the bar code, then inserts it into the variable text field of the current pattern. If more than one variable text field exists in the pattern, the operator must select which field is to receive the data.

## BENCHMARK 460+ ENHANCED COMMUNICATIONS

The BenchMark 460+ Enhanced Communications option allows you to use the controller's input/output signals and host communication capabilities to remotely control the marker.

The I/O port allows you transmit I/O signals between the controller and a remote I/O device. The I/O device can remotely select patterns to be loaded and start or abort the marking cycle. Output signals from the marker may be transmitted to the I/O device to report its status.

The TTL I/O port allows you to start printing operations using a Programmable Logic Controller (PLC) or by connecting a simple START PRINT contact closure.

The Host port allows an RS-232 device to transmit data, select patterns for printing, and control the marker operation. Optionally, the host interface supports RS-485 communications for networking multiple markers to the same controller.

### I/O Control Signals

The TMC420 is configured for DC I/O only. The TTL I/O Port may be used to connect a remote pushbutton control for Start Print and Abort commands. The I/O Port may be used to connect a PLC or other DC I/O source. The I/O Port allows remote control of pattern selection, printing, aborting, placing the marker online, and monitoring of the Ready and Done output signals. Cable connectors and connector pins are supplied with the controller for constructing appropriate interface cables.

START PRINT ..... Input signal, begins print cycle  
SEL\_0, 1, 2, 3 \* ..... Input signals, remote pattern selection (15\* max.)  
SEL\_3 \* ..... Input signal, marker online  
ABORT ..... Input signal, aborts print cycle  
Input Comm ..... For all inputs (+ or – supply)  
READY ..... Output signal, ready for message or start print  
DONE ..... Output signal, print cycle complete  
Output Comm ..... For all outputs (+ or – supply)

\* System software allows SEL\_3 signal to be configured for remotely selecting patterns or for remotely placing the marker online. If used for marker online, pattern selection is reduced to 7 patterns (max).

# BenchMark460 Marking System

---

## BENCHMARK 460+ COMMUNICATIONS (continued)

### Serial Interface

The Host Port is used for RS-232 and RS-485 communications with serial devices such as a host computer or bar code scanner. Up to 31 controllers may be used in a multi-drop configuration using the RS-485 interface. The host computer can load patterns, download messages, place the marker on/offline, and monitor system errors. (See *Serial Communications* for details.)

### Serial Communications

The Host Port may be used for either RS-232 or RS-485 communication. The RS-232 interface is most often used with remote devices such as bar code readers or host computers. The RS-485 interface is normally used for long transmission distances or multi-drop networks of up to 31 TMC420 controllers. The serial port may be configured to communicate using either the Telesis Programmable Protocol or Telesis Extended Protocol. The following describes the serial data character format on all transmissions to and from the TMC420 controller.

- Asynchronous
- 1200, 2400, 4800, 9600, or 19200 baud-host
- One Start Bit
- One or Two Stop Bit(s)
- Seven or Eight Data Bits
- None, Even or Odd Parity

### Programmable Protocol

Programmable Protocol is used where very simple one-way communications are required (such as with bar code scanners). Programmable Protocol provides no error checking or acknowledgment of the transmitted data. Note that XON/XOFF Protocol applies even when Programmable Protocol is selected.

**Starting Character** specifies where the software begins to count character positions. This number must be entered in ASCII decimal format such as 2 for STX.

**Terminating Character** identifies the end of transmitted string (usually ASCII carriage return character, decimal 13).

**Character Position** counted from the starting character ignoring all characters preceding it.

**Character Length** accepts variable length messages (if set to 0) or messages of a pre-specified, fixed number of characters.

**Ignore Character** identifies the character to ignore when sent from the host (usually ASCII line feed character, decimal 10).

**Message Type** allows message-type recognition which defines how the marking system will use data it receives from the host.

**P** loads a specific pattern identified by data extracted from host

**V** updates first variable text field with data extracted from host

**1** overwrites first text field with data extracted from the host

**Q** updates text in first query buffer with data extracted from host

**0** indicates that host will provide message type, field number (if applicable), and data; delegates message type selection to the host on message-by-message basis. The host message must use the format **Tnn<string>** where:

**T** = P, V, 1, or Q to indicate the message type.

**nn** = two-digit number to indicate field number or query text buffer where data will be placed. Note that a number is not used with Message Type P.

**<string>** = pattern name (Message Type P) or field data (Message Types V, 1, or Q), as applicable.

## BENCHMARK 460+ COMMUNICATIONS *(continued)*

### Extended Protocol

Extended Protocol includes error checking and transmission acknowledgment. It should be used in applications where serial communication is a vital part of the marking operation. Extended Protocol must be used in multi-drop applications.

All communications are carried out in a master-slave relationship with the host being the master. Only the master has the ability to initiate communications. If the host does not receive a response within three seconds, it should re-transmit its original message. If no response is received after three tries, it should declare the link to be down.

The following describes the message format as sent from the master to the TMC420 controller.

**SOH TYPE [##] STX [DATA] ETX BCC CR**

where:

**SOH** ASCII Start of Header character (001H). The controller ignores all characters received prior to the SOH.

**TYPE** A single, printable ASCII character that defines the meaning (type) and content of the message downloaded from the host, where:

- 1** overwrites the specified field of currently loaded pattern, using the format **1nn<string>** where nn is the field number.
- V** updates specified variable text field of currently loaded pattern, using the format **Vnn<string>** where nn is the field number.
- Q** updates specified query buffer with the data received from host, using the format **Qnn<string>** where nn is the buffer number.
- P** specifies pattern name to be loaded for printing
- O** resets marker and places it online
- G** initiates a print cycle to mark the currently loaded pattern
- I** requests the marker output status; returns a single-digit hexadecimal value to report state of READY and DONE:

Returned Value	DONE	READY
0	off	Off
1	off	ON
2	ON	Off
3	ON	ON

- S** requests the marker error status; returns a value that represents a particular type of error:

Returned Value	TYPE OF ERROR
0x0000	(no error)
0x0001	ONLINE_ERROR
0x0002	PATTERN_LOAD_ERROR
0x0004	DISALLOWED_NO_PATTERN
0x0008	DISALLOWED_OFFLINE
0x0010	PATTERN_FIELD_ERROR
0x0020	MARKER_ABORTED_ERROR
0x0080	PIX_OUT_OF_RANGE_ERROR
0x0100	RAM_ERROR
0x0200	SN_RANGE_ERROR

**##** Two optional ASCII decimal digits that specify the Station ID number for use in multi-drop network applications. The ID may range from 00-31. Note that "00" is reserved for applications where only one controller is used. In such applications, this field may be eliminated and "00" will be assumed.

**STX** ASCII Start of Text Character (002H).

**[DATA]** Optional field that may be required for certain message types.

**ETX** ASCII end of text character (003H).

**BCC** Optional Block Check Code that is generated and sent to improve link reliability by providing fault detection. The BCC is calculated by taking an eight bit addition of the TYPE and DATA characters and transmitting them as a three digit ASCII decimal number in the range from 000 to 255. If the sum is greater than 255, the most significant bit overflows and is discarded.

**CR** ASCII Carriage Return Character (00DH).

# ***BenchMark 460 Marking System***

---

## **TRADEMARKS**

**Telesis** and **BenchMark** are registered trademarks of Telesis Technologies, Inc. in the United States and/or other countries.

**NEMA** is the registered trademark and service mark of the National Electrical Manufacturers Association. .