

SYSTEM OVERVIEW

The Telesis®FQ10 is one laser in a family of maintenance-free, Q-switched, Ytterbium fiber lasers designed for marking applications. These lasers deliver a high power laser beam directly to the marking head via a flexible, metal-sheathed fiber cable. The fiber based optical design and rugged mechanical design allows the Telesis FQ10 to operate in an industrial environment where shock, vibration, and dust are a concern.

The FQ10 unique design allows for a remote beam delivery system. The galvanometer package is attached to a fiber-optic delivery system from a remote laser engine. This allows the overall package to be very small and modular.

The FQ10 fiber laser offers these advantages:

- Standard 115/230 VAC operation
- Over 50,000 hours of reliable, maintenance-free performance
- Compact size and modular construction
- Output laser beam delivery via a fiber optic cable
- Exceptional beam quality and stable output power
- Active AO Q-switching
- Display for monitoring actual laser power
- Display for monitoring hours of operation
- Sealed head to prevent dust contamination in optical chamber
- Visible red diode for aiming and dry run operations
- Air cooled
- DoD-compliant Unique Identification (UID) marking

SYSTEM CONFIGURATION

The FQ10 is available in two configurations. One is capable of marking only stationary objects. The other is capable of marking objects while they are moving (i.e., mark-on-the-fly operation). The basic laser system consists of the following components.

Laser Controller – contains the laser source unit, circuit boards, electrical components, and the operator console

Fiber Optic Cable Assembly – with optical isolator

Laser Marking Head – includes the shutter assembly, visible red aiming diode, galvanometer assembly, and flat-field lens

Software – Merlin®II LS Laser Marking Software

System Computer – supplied by Telesis or by customer

The modular design allows for major components to be easily replaced and returned to Telesis if required.

FQ10 Laser Marking System

SYSTEM SPECIFICATIONS

Compliance	CDRH, CSA
Laser Type	Q-switched Ytterbium fiber
Wavelength	1060 nanometers (± 10 nm)
CW Average Power.....	10 watts
Long Term Output Power Drift...	< $\pm 5\%$
Avg. Power Consumption.....	< 350 watts
Expected Diode Lifetime	> 50,000 hours
Input Power	95 to 250 VAC, 50/60 Hz
Supply Voltage Fluctuation	< $\pm 10\%$ with clean ground line
Operating Temperature.....	18° to 35°C (65° to 95°F)
Recommended Temperature....	20° to 25°C (68° to 77°F)
Ambient Relative Humidity	10% to 85% non-condensing

SYSTEM OPTIONS

- Desktop computer or notebook computer with powered cardbus-to-PCI expansion enclosure
- Remote pushbutton station (start/abort)
- Externally-mounted focus-finder diode
- Mark-on-the-fly kit to interface with customer-supplied encoder for marking objects in motion (linear or circular)
- I/O options (see *Remote Communications* for details):
 - TTL via PCI-DIO24 Board (Kit #53920)
 - Opto-isolated via Merlin DCIO Module (Kit #53928)
 - Two-axis Controller (for auxiliary axes; additional I/O)
- Programmable tool post for vertical (z-axis) adjustment (requires two-axis controller)
- Rotary drive fixture for rotational (theta-axis) adjustment (requires two-axis controller)
- Workstation / work area enclosure
- Fume extraction systems

SYSTEM SETUP

The following procedures are listed for reference only to provide a general overview of the installation process. Refer to the *FQ10 Installation & Maintenance Manual* for complete installation details.

Do not connect any power cable to power source until all system connections are made.

1. Equipment should remain powered down and in OFF position until mounting is complete.
2. Place computer, monitor, keyboard, and laser controller in desired location. Locate controller as close as practical to laser marking head – typically within 5m (16 feet).
 - ▶ Ensure sufficient clearance on sides of laser controller (approx. 100 mm or 4 in.) to allow for air circulation. **Do not block the vented openings on the laser controller.**
 - ▶ A minimum distance of 200mm (8 in.) should be allowed at the rear of the laser controller to allow for a proper bend radius of the fiber optic cable.
3. Place the laser marking head on selected mounting surface.
 - ▶ **Do not bend or kink fiber optic cable.** The fiber optic cable will tolerate approximately 300 mm (12 in.) diameter bend without damage.
 - ▶ **Allow a minimum distance of 200 mm (8 in.) at rear of the laser marking head.** This will provide sufficient room for a proper bend radius of fiber optic cable.
 - ▶ Ensure sufficient clearance on all sides of laser marking head (approx. 100 mm or 4 in.) to allow for air circulation.
 - ▶ Mounting holes are tapped for metric threads. The mounting pattern is a four (4) hole rectangular pattern 2.0 in. wide by 3.75 in. long (50.8 x 95.25 mm). The holes are tapped 0.30 in. (7.62 mm) deep for M6-1.00 bolts. **Mounting bolts must not extend into the laser marking head as to interfere with the internal components.**
 - ▶ The leading edge of the mounting plate must not extend more than .375 in. (9.5 mm) forward of the first set of holes to allow clearance for the beam output lens.
 - ▶ As viewed from the back of the laser marking head, the center of the output beam is 3.125 in. (79.375 mm) forward of the first set of mounting holes and 0.732 in. (18.61 mm) inward from the left side set of mounting holes.
4. Secure laser marking head to mounting fixture using four M6-1.0 bolts. Torque to 80 in-lb (9.04 N-m). **Do not over tighten bolts.**
5. Select proper fuse arrangement for the laser controller. Refer to the *FQ10 Installation & Maintenance Manual*. Connect power cable controller.
6. Connect all remaining cables, as applicable.
7. Refer to *FQ10 Operation Supplement* for proper startup procedure. Refer to the *Merlin II LS Operating Instructions* for complete information on using system software.

FQ10 Laser Marking System

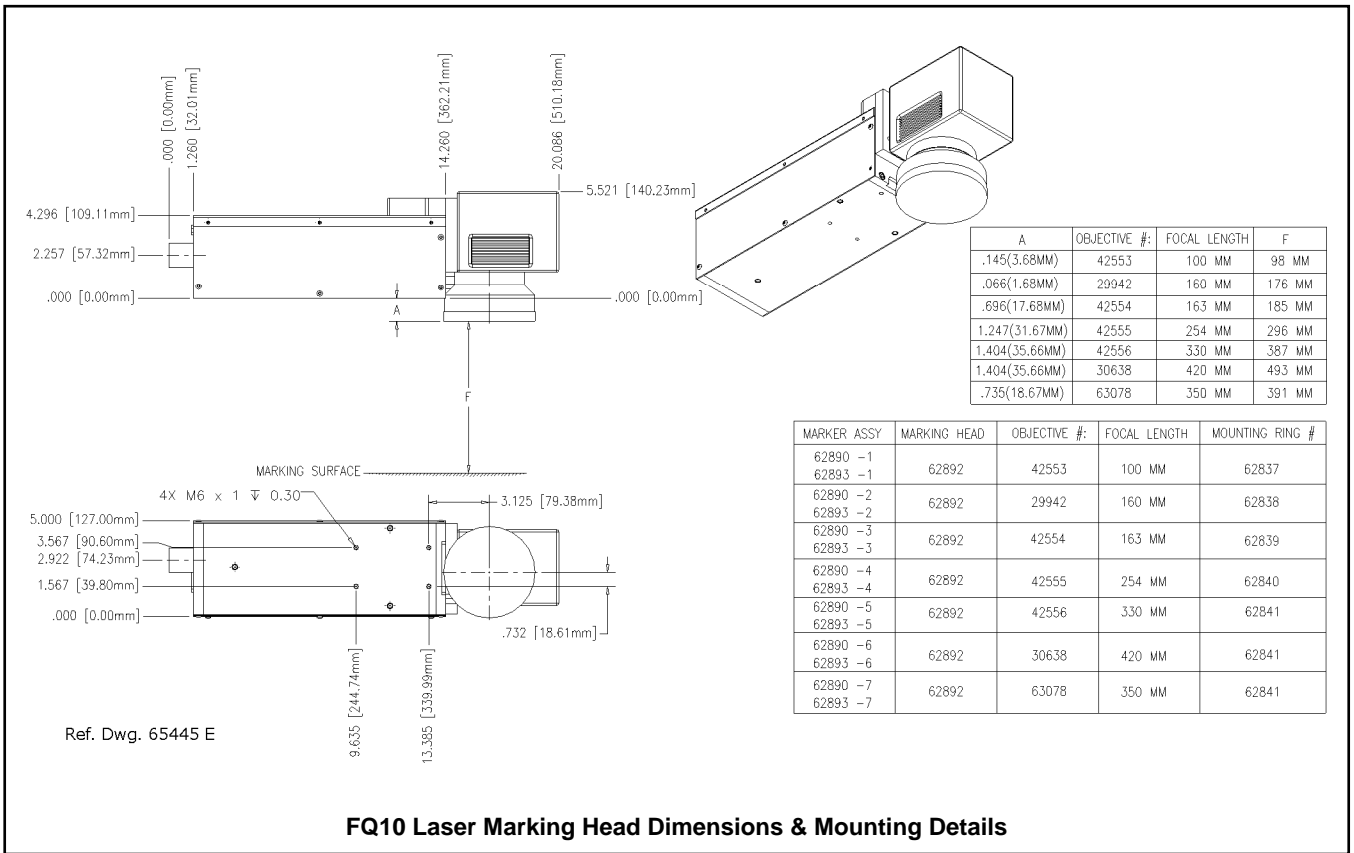

FQ10 Laser Marking Head Dimensions & Mounting Details

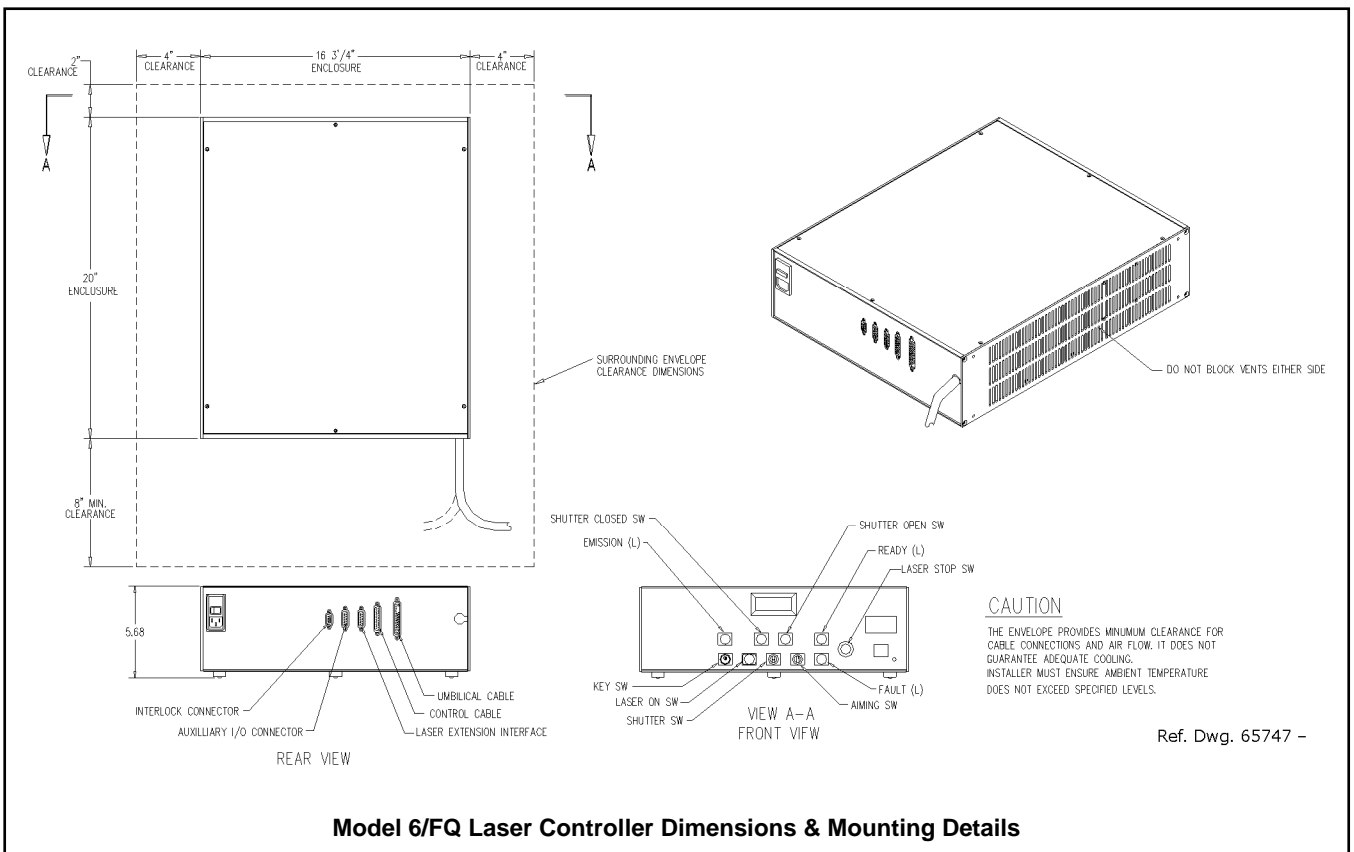

Model 6/FQ Laser Controller Dimensions & Mounting Details

FQ10 Laser Marking System

FQ10 LASER MARKING SYSTEM LABELS

The following illustration shows the labels and their locations on the FQ10 laser marking head and Model 6/FQ laser controller. Please familiarize yourself with the laser labels and their locations prior to operating the laser marking system.

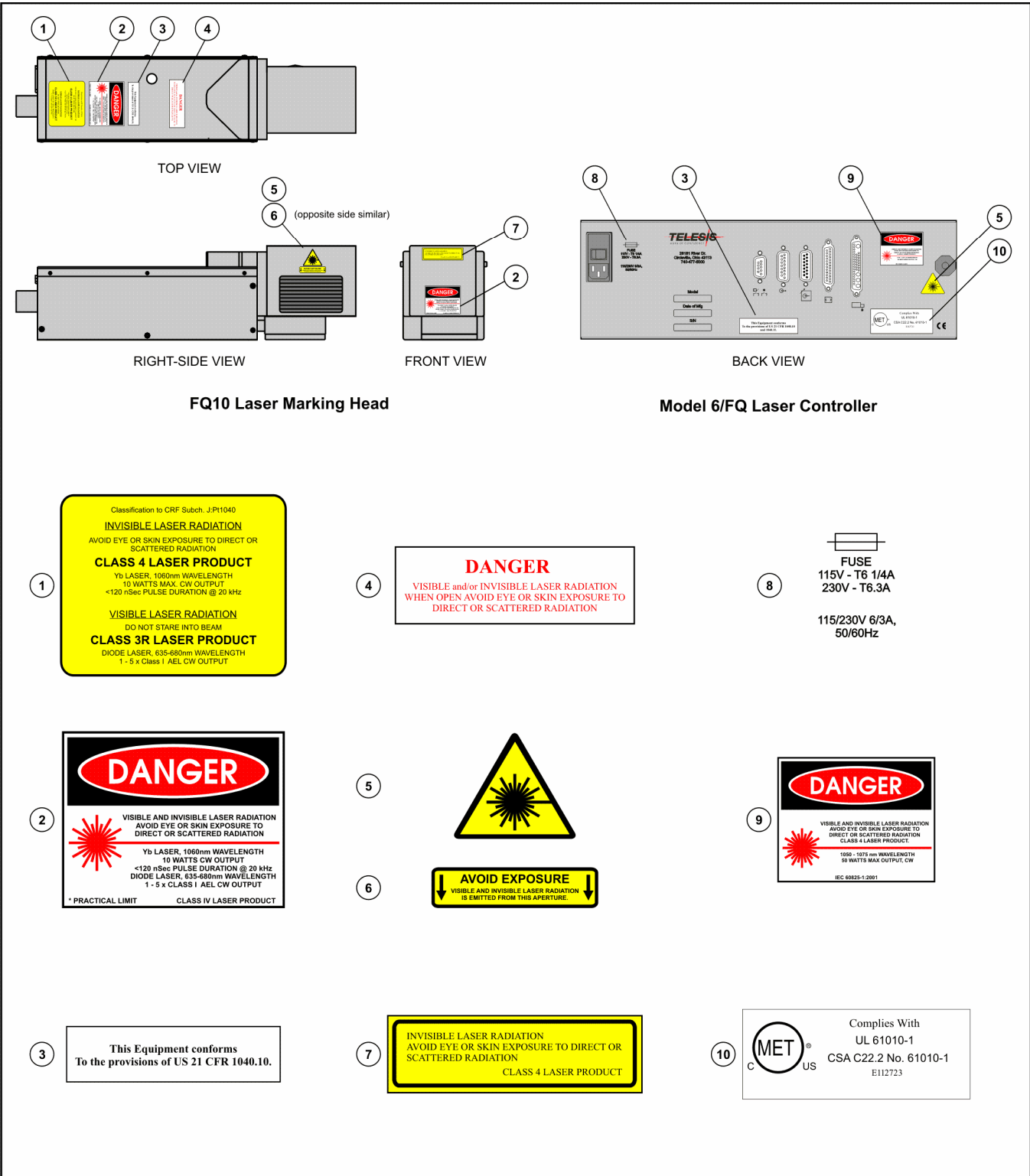

FQ10 LASER MARKING HEAD

The laser marking head includes the shutter assembly, visible red aiming diode, circuit board, galvanometer assembly, and the flat-field lens. The beam collimator and isolator (at the end of the fiber optic cable) are enclosed within the laser marking head.

FQ10 Laser Marking Head Specifications

- Dimensions (L x W) 510.184 x 127.000 mm
(20.086 x 5.000 in.)
- Dimensions (H) Dependent on lens selection:
 100mm: 144.120 mm (5.674 in.)
 160mm: 142.113 mm (5.595 in.)
 163mm: 158.115 mm (6.225 in.)
 254mm: 172.110 mm (6.776 in.)
 330mm: 177.622 mm (6.993 in.)
 350mm: 159.106 mm (6.264 in.)
 420mm: 177.622 mm (6.993 in.)
- Mounting Weight..... approx. 6.82 Kg (15 lbs.)
- Mounting Holes our factory-tapped M6-1.00
- Positioning..... visible (red) aiming diode
- Field Resolution 16 bit (65535 data points)
- Galvanometer Repeatability.... < 22 micro radian
- Marking Field Size lens-dependent, see chart
- Fiber Optic Cable 5 m (16.4 ft.)
- Laser Marking Head Cable 5 m (16.4 ft.), detachable
- Laser Extension Cable 3.05 m (10.0 ft.), detachable

Visible Red Aiming Diode

The laser marking head produces a visible red diode that may be viewed on the work surface without the need for protective safety goggles. This provides a safe and convenient aid for laser setup and part programming. Since the red beam is located *after* the shutter, the aiming diode may be used with the shutter opened or closed. Additionally, the visible red beam may be used with the lasing beam during the marking cycle. **Note that protective eyewear must always be worn when the laser is in operation.**

Marking Field Size

The size of the marking field is dependent on type of lens installed on the laser marking head. See *Flat-Field Lens*.

Marking Depth

Simple laser parameters can be operator programmed to create depths ranging from simple surface discoloration, shallow laser etching, or deep laser engraving. Marking depth is dependent on several factors including material, lens type selected, and laser marking parameters. Please contact Telesis for the proper setting for your specific application.

Flat-Field Lens

The flat-field lens is key to the marking performance of the system. This is the final coated optical lens that the beam will pass through before it strikes the marking target. This lens is called a flat field lens because when the beam is focused, the focus lies in a plane perpendicular to the optical axis of the lens. To protect the final objective lens from dust and debris, a clear protective cover is inserted between the work area and the lens.

The following chart outlines the available lenses, the resulting image field (marking window) provided by the lens, and the working clearance (in millimeters and inches).

Lens	Image Field		Working Clearance	
	(mm)	(in.)	(mm)	(in.)
100 mm	65 x 65	2.56 x 2.56	98	3.86
160 mm	90 x 90	3.54 x 3.54	176	6.93
163 mm	110 x 110	4.33 x 4.33	185	7.28
254 mm	175 x 175	6.89 x 6.89	296	11.65
330 mm	230 x 230	9.06 x 9.06	387	15.24
350 mm	250 x 250	9.84 x 9.84	391	15.39
420 mm	290 x 290	11.42 x 11.42	493	19.41

FQ10 Laser Marking System

MODEL 6/FQ LASER CONTROLLER

The laser controller houses the laser source unit, power supplies, circuit boards, programmable logic controller, control relay, cooling fan, a 115/230VAC IEC320 connector, and a front panel control module.

The laser source unit generates the lasing beam. Engineered for the greatest reliability and for ease of maintenance, the laser source is an easily replaceable sealed module with expected lifetime of greater than 50,000 operating hours.

Model 6/FQ Laser Controller Specifications

Dimensions (W x H x D).....	425.5 x 144.3 x 508.0 mm 16.75 x 5.68 x 20.00 in.
Surrounding Envelope.....	628.7 x 152.5 x 762.0 mm 24.75 x 6.00 x 30.00 in.
Weight	approx. 15 Kg (33 lbs.)
Cooling	air cooled, fan

Operator Control Panel

The front panel control module includes the system key switch, laser off push button, manual safety shutter control, function indicators, an LCD panel to monitor elapsed emission time, and an LED panel to monitor laser power.

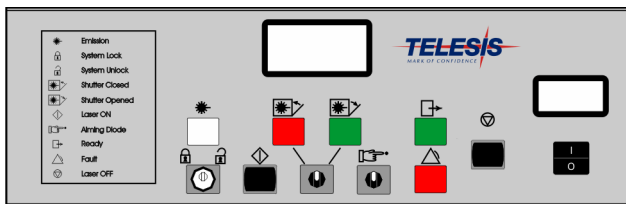

Model 6/FQ Laser Controller

Fiber Optic Cable Assembly

The lasing beam is delivered to the laser marking head from the laser controller through a fiber optic cable. One end of the fiber optic cable is permanently attached to the laser source unit inside the laser controller. The opposite end of the cable includes a beam collimator and isolator that is enclosed within the laser marking head assembly. The standard fiber optic cable for the FQ10 is 5 m (16 ft.) long.

Optical Isolator

To prevent back reflections an *optical isolator* is used in all standard FQ10 Laser Marking Systems. Installed on the laser marking head end of the fiber optic cable, the isolator functions as a one way check valve allowing laser light to exit the laser but not return to the laser's most sensitive optical components.

SYSTEM COMPUTER

The laser system requires an IBM-compatible computer for running the Merlin II LS Laser Marking Software. The system computer may be a desktop or a notebook computer and may be supplied by Telesis or by the customer.

If supplied by Telesis, the Laser/Galvo Controller board and the Merlin II LS is installed in the system computer prior to shipment and the entire unit is tested as a laser marking system. Warranty for the computer, keyboard, monitor, and peripherals default to the original equipment manufacturer.

If the system computer is supplied by anyone other than Telesis it must, at a minimum, meet the following specifications.

Operating System.....	Windows® 2000, Windows® XP, or Windows® Vista™ Business Edition
Operator Interface	Telesis Merlin II LS Laser Marking Software
Processor	Pentium® III with RAM as recommended per operating system
Hard Drive	2 GB Hard Disk Drive
External Drives	CD-ROM Drive
Peripherals	SVGA Color Monitor, Mouse, Keyboard, Laser/Galvo Controller Board, Video Board, One available RS-232 Serial Port, Two available USB Ports, Two available <u>full-height</u> PCI Slots*

* If the system computer is a notebook, expansion must be used to provide the PCI slots.

SYSTEM SOFTWARE

The powerful Telesis Merlin II LS Laser Marking Software is a Windows® based software package that comes standard with the laser marking system. It is a graphical user interface that makes marking pattern design quick and easy. The WYSIWYG (what-you-see-is-what-you-get) interface provides a to-scale image of the pattern as it is created. Just “click and drag” for immediate adjustment to field size, location, or orientation.

The Merlin II LS software includes tools to create and edit text at any angle, arc text, rectangles, circles, ellipses, and lines. Multiple fields may be grouped and saved as a block to form a logo. Existing DXF files can also be imported for marking. Non-printable fields can be created to clearly display a graphical representation of the part being marked.

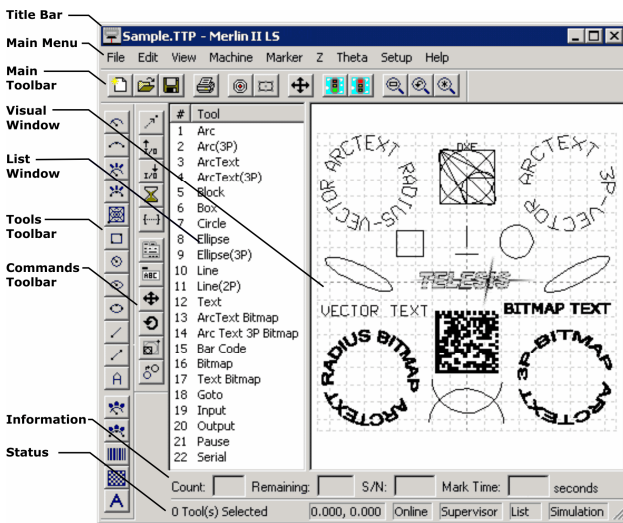

Merlin II LS User Interface

Merlin II LS Laser Marking Software Specifications

Operating System	Windows® 2000, Windows® XP, or Windows® Vista™ Business Edition
Font Generation	True Type Fonts
Barcodes and Matrix	2D Data Matrix, PDF417, BC 39, Interleaved 2 of 5, UPCA/UPCE BC 128, Maxi Code, Code 93, QR Code and others
Graphic Formats	Raster and Vector: BMP, GIF, JPG, WMF, EMF, DXF, CUR, ICO
Serialization	Automatic and Manual Input Host Interface Capable
Linear Marking	Scalable w/ Letter Spacing Control
Arc Text Marking	Scalable and Adjustable
Drawing Tools	Line, Rectangle, Circle, Ellipse

Remote Communications

The communication capability of the laser marking software allows you to control the laser from remote I/O devices. Remote communications can be performed by connecting to a Host computer, an optional I/O kit, or an optional two-axis Auxiliary Controller.

The rear panel of the controller also provides a connector to monitor output signals that report the status of the shutter, laser emission, and fault conditions.

Host Communications. Remote communications may be executed from a host computer using RS-232 or Ethernet (TCP/IP) connections to the system computer (i.e., the PC running the Telesis laser marking software). The software provides parameters to define the data transmitted to and from the host. For more information on using and configuring these parameters, refer to the *Merlin II LS Operating Instructions*.

I/O Kits. Telesis offers optional kits that provide programmable I/O signals in addition to the standard input signals (Go, Abort, Input 1 through Input 4) and standard output signals (Done, Ready, Paused, Output 1 through Output 3). For more information on connecting and using the additional I/O signals, refer to the I/O Installation Supplement provided in each of the kits.

- **Kit #53920** is available for all systems that use an *external computer*. It provides an additional 6 inputs and 6 outputs. It includes the I/O board, pre-installed SIPs resistor packs, software driver CD, and installation documentation. **This kit does not provide opto-isolated signals. Telesis does not endorse direct connection of I/O signals to the I/O board. Direct connections to high current/high voltage devices will damage the board.** The installer/integrator must provide opto-isolation between remote I/O devices and the I/O board.
- **Kit #53928** is available for all systems that use an *external computer*. It provides an additional 6 inputs and 6 outputs. It includes the I/O board, pre-installed SIPs resistor packs, software driver CD, Telesis Interface Module (#53423), two cable assemblies, and installation documentation. This kit provides opto-isolated signals between remote I/O devices and the I/O board using a Telesis interface module so additional I/O racks or opto-isolated board assemblies are not required.

Two-axis Controller. Telesis offers an optional two-axis controller for all laser systems that use the Merlin-II LS Laser Marking Software. The auxiliary controller provides an interface for connecting six input and six output signals to and from the laser marking system, and for connecting the optional auxiliary axes: vertical (Z) axis, rotational (Theta) axis, and linear (L1 and L2) axes.

Environmental considerations must be taken into account when installing the auxiliary controller concerning contaminants and EMI susceptibility. For details, refer to the *Auxiliary Controller Installation & Maintenance Manual* supplied with the controller.

FQ10 Laser Marking System

Communications Protocol

Two types of host interface are supported (RS-232 or TCP/IP) and two communication protocols are provided through the Merlin II LS laser marking software: Programmable and Extended.

Programmable Protocol. Programmable protocol provides one-way (receive only) communication with no error checking or acknowledgment of the transmitted data. You may use Programmable protocol to extract a continuous portion of a message string to print. This can be used with a host computer or a bar code scanner. Note that XON/XOFF Protocol applies even when Programmable Protocol is selected.

The Programmable Protocol Message Type identifies the type of message sent from the host. It determines how the marker uses the data it extracts from the host message string when Programmable Protocol is used.

- 49 Message type 49 ("1")** overwrites the content of the first text-based field in the pattern with the data extracted from the host message. Note that if the field contains message flags, they will be overwritten, not updated.
- 65 Message type 65 ("A")** updates the Offset Angle parameter with the data extracted from the host message. Syntax for the transmitted string is $\pm n$ where \pm is a positive or negative sign and n is an integer that represents the offset angle for the marking window.
- 72 Message type 72 ("H")** updates the Offset X/Y parameters with the data extracted from the host message. Syntax for the transmitted string is $\pm X.X, \pm Y.Y$ where \pm is a positive or negative sign, $X.X$ represents the X-axis offset distance, and $Y.Y$ represents the Y-axis offset distance.
- 80 Message type 80 ("P")** indicates the data extracted from the host message is the name of the pattern to be loaded.
- 81 Message type 81 ("Q")** updates the text in the first query text buffer (buffer 0) with the data extracted from the host message.
- 86 Message type 86 ("V")** updates the text in the first variable text field in the pattern with the data extracted from the host message.
- 118 Message type 118 ("v")** updates the first text field encountered in the pattern that contains a variable text flag that matches the specified string length.

If the host provides the message type within the transmitted text string, set the Programmable Protocol Message Type (on the software Host/Setup window) to Message Type 0 (zero).

- 0 Message type 0 (zero)** indicates that the host will provide the message type, field number (if applicable), and data (if applicable). This option allows more flexibility by delegating the message type selection to the host on a message-by-message basis. It also allows you to direct data to specific fields and/or query text buffers.

The host can use Message Type 0 to provide data to the marking system. The marking system will insert data transmitted with the message into the appropriate location.

Extended Protocol. Extended protocol provides two-way communication with error checking. It is designed to provide secure communications with an intelligent host device using pre-defined message formats and response formats. It also provides error checking using a block check code to detect faults in the transmitted messages and to verify the data is properly received.

The Extended Protocol Message Type determines how the marker uses the data it extracts from the host message string or from the laser marking system software, as applicable.

- 1 Message Type 1** can provide data to a text string in the pattern or poll the pattern for data.
- A Message Type A** can provide data to the system Offset Angle parameter for the marking window or poll the system for data.
- E Message Type E** allows the host to take the machine offline. It also provides the option of displaying an error message box with the provided data string.
- V Message Type V** can provide data to a variable text string in the pattern or poll the pattern for data.
- P Message Type P** can load a pattern or poll the system for the current pattern name.
- O Message Type O** places the marker online. This allows a host computer to reset. For example, this may be used to recover from a power outage when the marker is unattended.
- G Message Type G** initiates a print cycle.
- Q Message Type Q** can provide data to the system query text buffer or poll the system for data.
- H Message Type H** can provide data to the system X/Y Offset parameters or poll the system for data.
- S Message Type S** is used to poll the system for the machine status. The machine status is returned to the host in an eight-character hexadecimal mask.
- I Message Type I** is used to poll the system for the I/O status.

TRADEMARKS

Telesis and **Merlin** are registered trademarks of Telesis Technologies, Inc. in the United States and/or other countries.

Pentium is a registered trademark of Intel Corporation in the United States and other countries.

Vista is a trademark of Microsoft Corporation in the United States and other countries.

Windows is a registered trademark of Microsoft Corporation in the United States and other countries.